

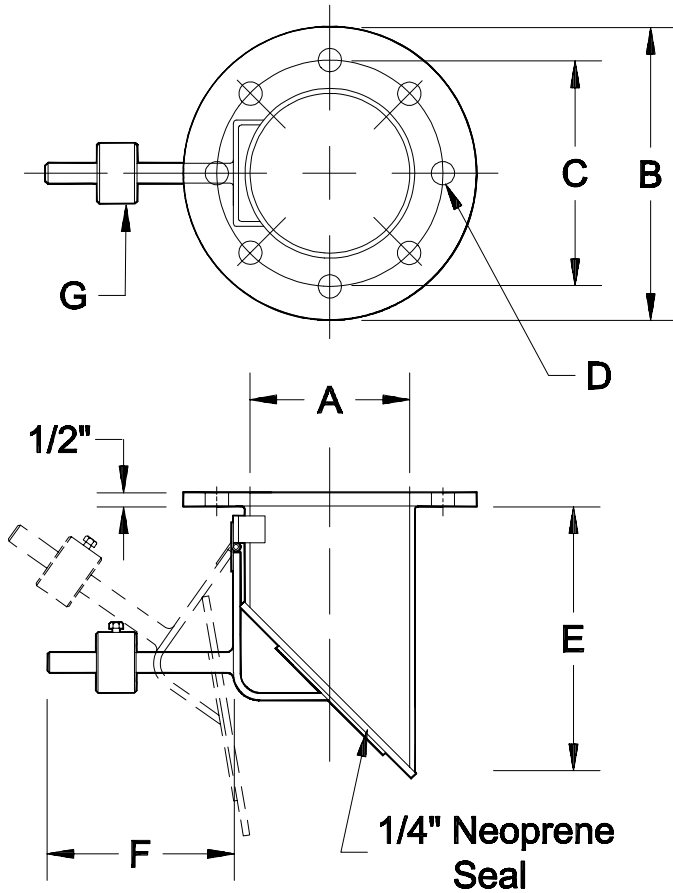

NATIONALTURBINE CORPORATION
 374 Northern Lights Drive
 Syracuse, NY 13212
 888-293-7434 fax 315-455-5545
 www.nationalturbine.com
 sales@nationalturbine.com

PRODUCT DATA VACUUM EQUIPMENT

COUNTER WEIGHTED SELF DUMPING VALVES



COUNTER WEIGHTED DISCHARGE VALVES ARE DESIGNED TO ALLOW CONTINUOUS DUMPING OF COLLECTED MATERIAL.

THE ADJUSTABLE COUNTER WEIGHT EASILY ADJUSTS THE FORCE REQUIRED TO OPEN THE VALVE.

MATERIALS OF CONSTRUCTION

- Tube - Thin Wall Tubing
- Counter Weight - HRS
- Valve Construction - 11 ga. HRS
- Valve Seal - 1/4" Neoprene Rubber
- Connection - 125# ANSI Flange or NPT
- Valve Assembly - #10-24 Plated Bolts
- Finish - Industrial Enamel

MODEL	A	B	C	D	E	F	G	WGT.
CWV-300	3	7-1/2	6	3/4 - 4	6	6	1-1/4 - 9 oz	11 lbs
CWV-400	4	9	7-1/2	3/4 - 4	6	6	1-1/4 - 9 oz	13 lbs
CWV-600	6	11	8-1/2	7/8 - 8	10	7	2-1/2 - 18 oz	17 lbs