

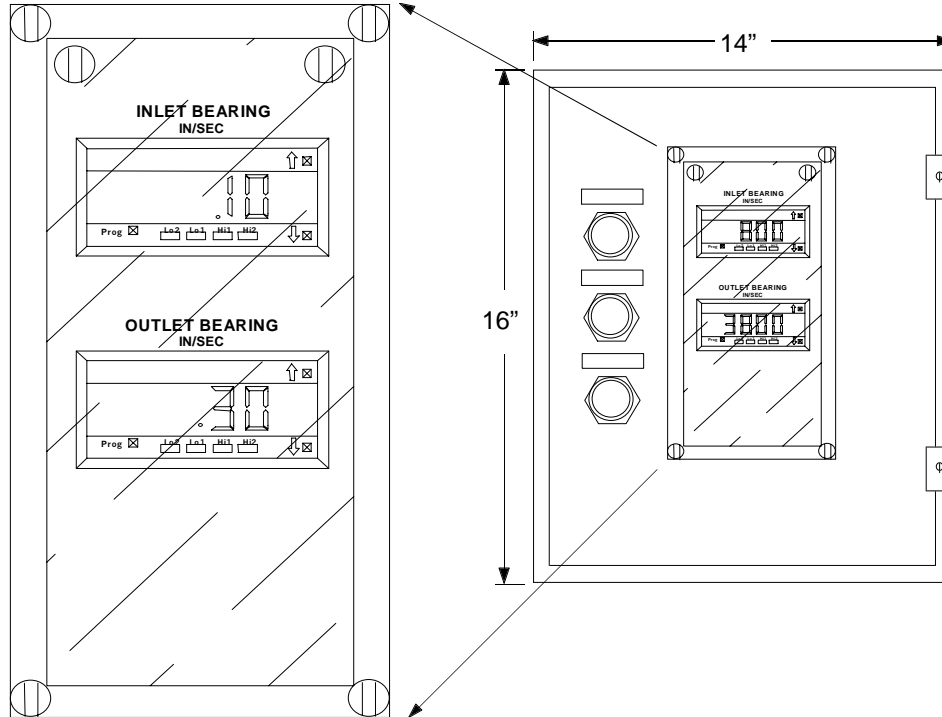

NATIONALTURBINE CORPORATION  
374 Northern Lights Drive  
Syracuse, NY 13212  
888-293-7434 fax 315-455-5545  
www.nationalturbine.com  
sales@nationalturbine.com

## CONTROLS

### VIBRATION PROTECTION, BEARING MOUNTED



#### **PROTECTION**

- Bearing high vibration warning & shutdown

#### **FUNCTION**

- Programmable set points for both warning and shutdown levels

#### **DISPLAY**

- Inlet & outlet bearing vibration

#### **ANNUNCIATION**

- Pilot lights indicating shutdown
- Digital meter LED indicates warning level exceeded

#### **ENCLOSURE**

- NEMA 12 size in inches 16H x 14W x 8D

#### **PANEL COMPONENTS**

- Digital vibration meter for each bearing
- Adjustable start delay timer
- Two red LED type full voltage pilot lights
- RESET push button

#### **FIELD COMPONENTS**

- Vibration transmitter for each bearing furnished loose

PART NUMBER- VTRANSB

COPYRIGHT 1998-2002 NATIONAL TURBINE CORPORATION

013102

VP-7055-00